

HIDRANTNA NIŠA | HYDRANT NICHE  
TLOCRT | PLAN VIEW  
M 1:50

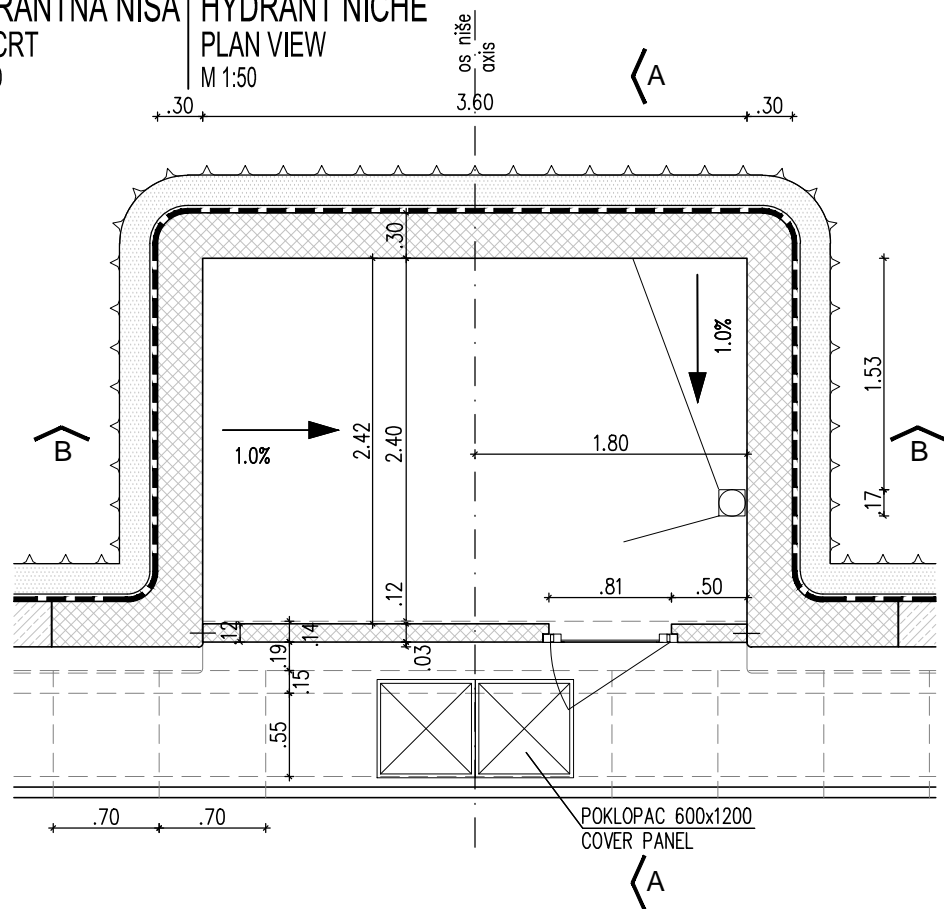

PRESEK A-A | CROSS SECTION A-A  
M 1:50

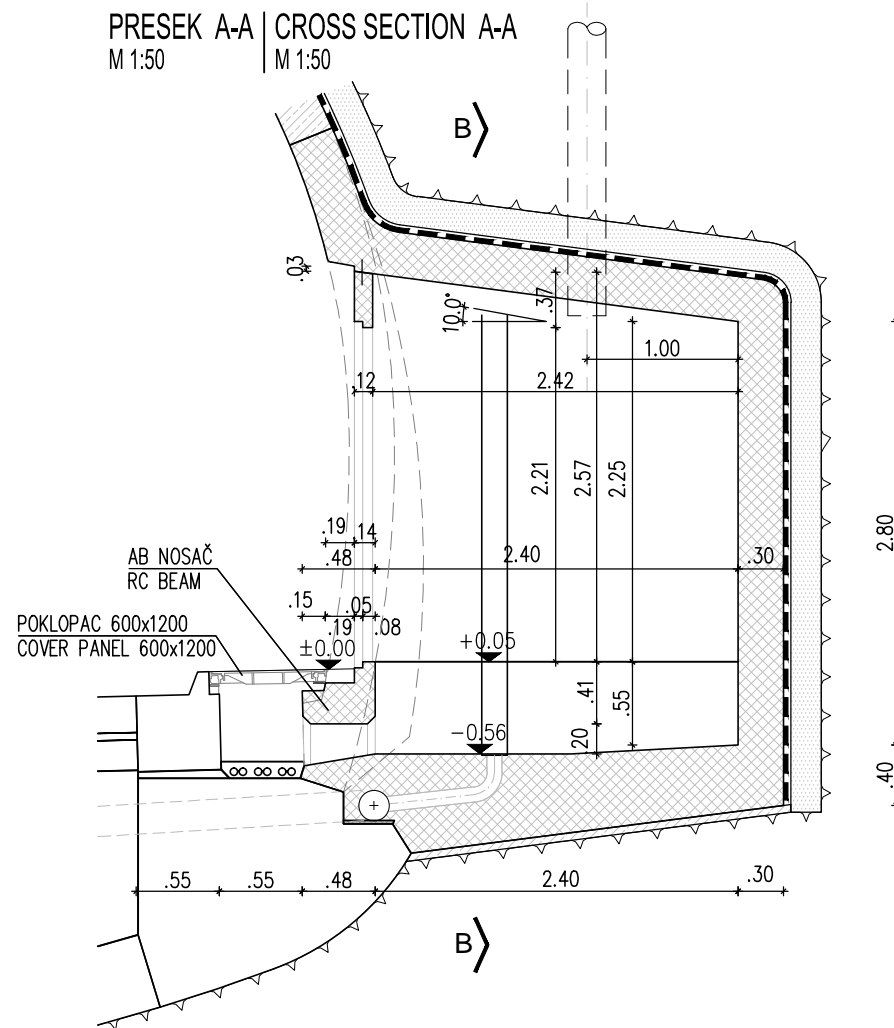

PRESEK B-B | CROSS SECTION B-B  
M 1:50

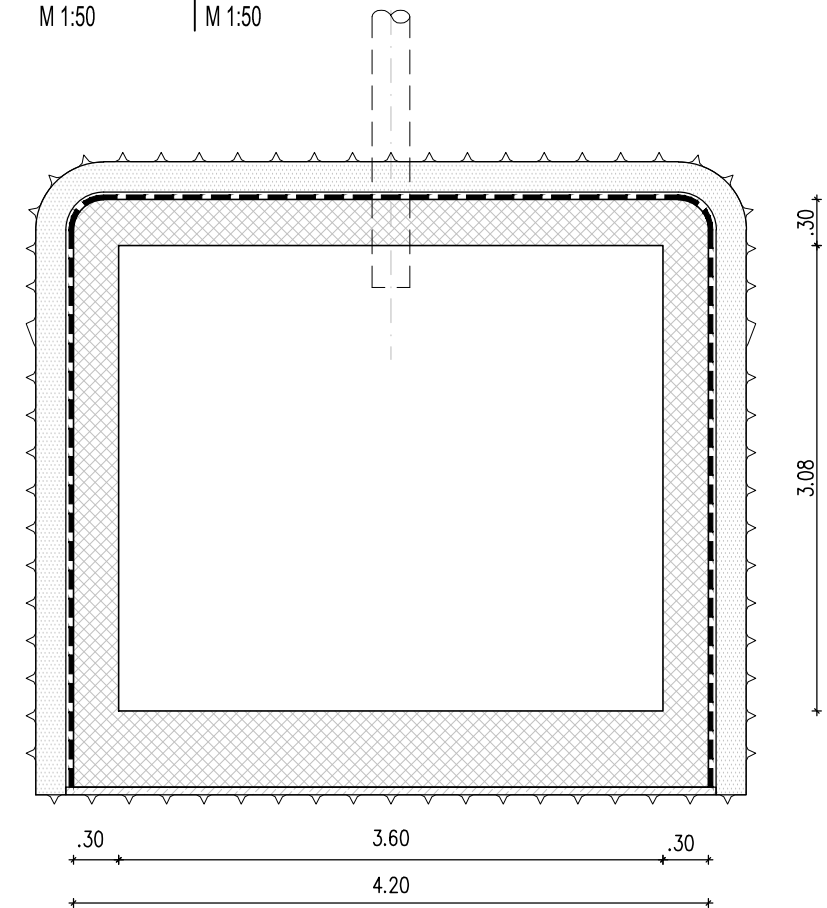

PROTIVPOŽARNA NIŠA - PPN | FIRE FIGHTING NICHE - PPN  
TLOCRT | PLAN VIEW  
M 1:50

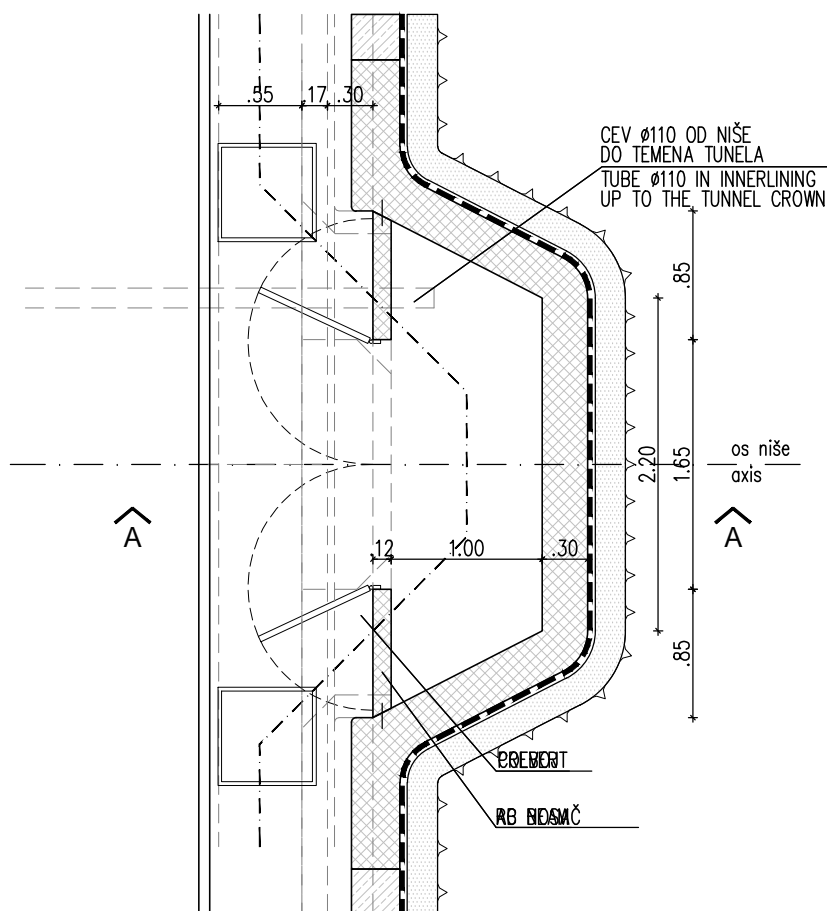

PRESEK A-A | CROSS SECTION A-A  
M 1:50

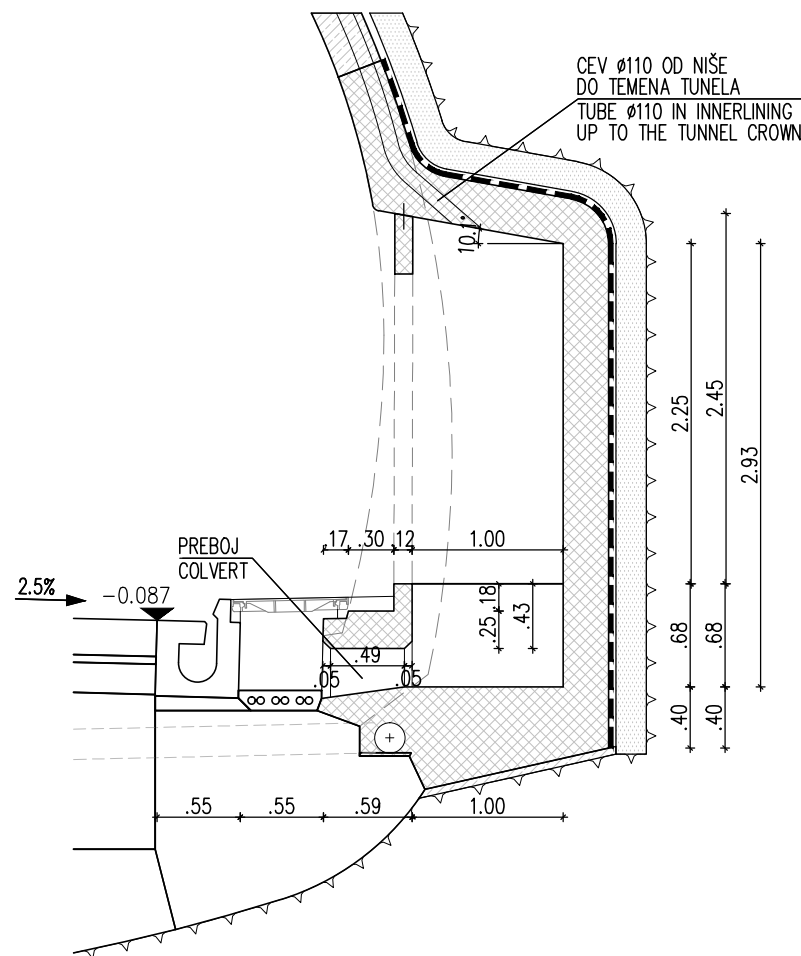

br./no.	promena/change	datum/date	ime/name
Klijent/client: 			
naslov/title: SRSDD Standardni crteži putnih detalja u Republici Srbiji SRSDD Serbian road standard detail drawings			
crtež/drawing: Niše Niches			
razmera/scale: 1:50	datum/date: 30.04.2012	strana/page: 7.8.1	